

P-type Coaxial HPGe Detectors for High Performance Gamma Spectroscopy in the Energy Range of ~40 keV and Up.

The majority of gamma spectroscopy applications such as those found in counting laboratories involve the energy range ~40 keV upward. ORTEC GEM and Profile Series GEM detectors are designed to cover this energy range. The Profile GEM-FX Series extends this lower energy cut off to 10 keV and above. (A separate guide is available for the Profile GEM Series.)

All GEM Series feature:

- Efficiencies to 150%, higher on request.
- Excellent energy resolution and peak symmetry..
- Specified crystal dimensions in Profile models.
- SMART bias options.
- Harsh Environment (-HE) option.
- Low-background carbon fiber endcap options.
- PLUS preamplifier option for ultra-high-rate applications.
- Huge configuration flexibility: PopTop, Streamline and mechanically cooled options.

ORTEC offers GEM Series HPGe detectors with relative efficiencies¹ from 10% to 150% and beyond. The detectors are manufactured from ORTEC-grown germanium crystals processed in our advanced manufacturing facility in Oak Ridge, TN. The detectors are fabricated from P-type germanium with an outer contact of diffused Li and an inner contact of ion-implanted boron.

ORTEC maintains a large stocklist of GEM detectors. Some of these have "super specifications," that is, a warranted energy resolution better than the usual GEM warranted specifications.

The Following Specifications are Provided for each GEM Detector

- Energy resolution full-width half-maximum (FWHM) at 1.33-MeV and optimum shaping time.
- Relative Photopeak efficiency at 1.33 MeV.
- Peak-to-Compton ratio at 1.33 MeV.
- Peak shape ratio for the full-width tenth-maximum to the full-width half-maximum at 1.33 MeV.
- Energy resolution at 122 keV at optimum shaping time.

Configuration Guidelines

PopTop or Streamline (non-PopTop) Configuration

The essence of a PopTop detector system is that the HPGe detector element cryostat, preamplifier, and high voltage filter are housed in a detector "capsule" which is then attached to an appropriate cryostat (Figure 2.)

In so called Streamline systems, the detector capsule is NOT demountable. Detector capsule and cryostat share the same vacuum. In configuration terms, this requires a cryostat or cryostat/dewar selection with the cryostat having a matching diameter to the capsule endcap. A cryostat must always be ordered with a Streamline capsule, because they are integral.

The actual PopTop capsule has its own vacuum. It can be mounted on any of the available cryostats, cryostat/dewar combinations, or the X-COOLER II mechanical cooling system.

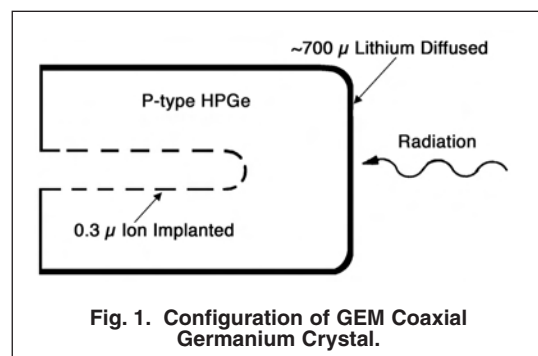

¹By convention, HPGe detectors are characterized by "relative efficiency". Relative efficiency is defined as the efficiency of a point Co-60 source at 25 cm from the face of a standard 3-inch x 3-inch right circular cylinder NaI(Tl) detector. "IEEE Test Procedures for Germanium Detectors for Ionizing Radiatio," ANSI/IEEE Standard 325-1986.

GEM Series Coaxial HPGe Detector Product Configuration Guide

Steps to Configure Your ORTEC HPGe Detector

1) Configure the Detector Model

- Capsule type (PopTop or Streamline)
- Ge Crystal efficiency and specifications
- Endcap and window
- Mount
- Preamplifier
- High Voltage Filter
- Cable Package

Options are available for the detector model that can change specific materials used in the construction of the detector endcap, cup, and mount. Preamplifier options are also available.

2) Configure the Cryostat/Dewar Model

- Vertical Dipstick style (separate Dewar)
- Horizontal Dipstick style (separate Dewar)
- Portable with all-position or multi-position cryostat/dewar models
- Downlooking designed to be oriented with the detector pointing down
- Sideloooking designed to be oriented with the detector horizontal at the bottom of the dewar
- "J" configurations designed with the detector attached near the bottom of the dewar and a right angle bend in the cryostat orienting the detector to look up.

A cryostat and dewar or other cooling device are required for operation.

If a PopTop detector has been selected, you can choose a PopTop style cryostat, cryostat/dewar combination or the X-COOLER II mechanical cooler.

If a Streamline detector has been selected, you must choose a cryostat or cryostat/dewar model for the detector to be mounted on and vacuum sealed. The cryostat or cryostat/dewar combination diameter must match the endcap diameter of the selected detector.

Detector Options

Harsh Environment Option (-HE)

The Harsh Environment option is a rugged carbon fiber endcap with a sealed electronics housing featuring a replaceable desiccant pack which ensures that the electronics stay 100% dry and indicates when it needs to be replaced.

GEM series detectors in PopTop capsules of 76 mm diameter or larger can be supplied with this option.

Ultra-High Count-Rate Preamplifier Option (-PL)

The Ultra-High Count-Rate Preamplifier (transistor-reset preamplifier), which can handle input count rates up to 1,000,000 counts/s at 1 MeV, offers the added benefit of having no feedback resistor.

SMART-1 Option (-SMP)

The SMART-1 option monitors and reports on vital system functions, and can save authentication codes and report the code at a later time. It has the high voltage included, so none of the instruments require an external high-voltage power supply.

The SMART-1 is housed in a rugged ABS molded plastic enclosure and is permanently attached to the detector endcap via a molded-strain-relieved sealed cable. This eliminates the

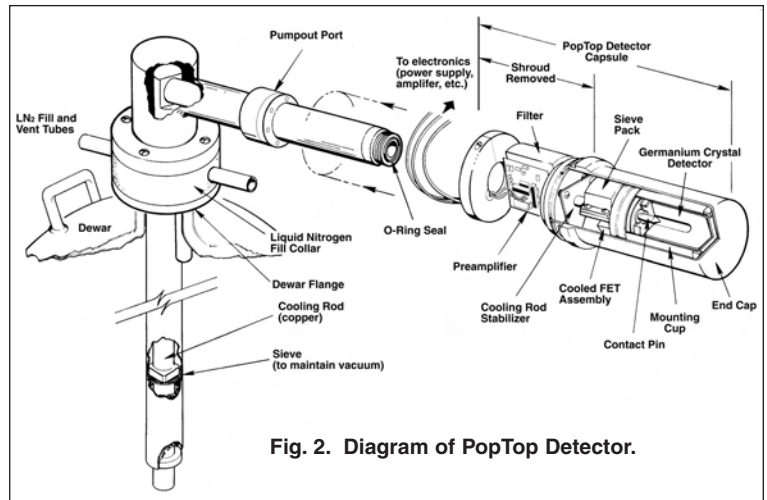

Fig. 2. Diagram of PopTop Detector.



Fig. 3. -HE Detector Option (Carbon Fiber Endcap).



Fig. 4. SMART-1 Detector Interface Module.

GEM Series Coaxial HPGe Detector Product Configuration Guide

possibility that the detector will suffer severe damage from moisture leaking into high-voltage connectors. The SMART-1 can be positioned in any convenient place and does not interfere with shielding or other mounting hardware.

Remote Preamplifier Option (-HJ)

This option allows all the preamplifier and high voltage connections to be outside a shield and removes the preamplifier and high voltage filter from the “line-of-sight” to the Ge crystal. For low background applications, this option eliminates any possible preamplifier or high voltage filter components that may add to the background inside a shield.

Low-Background Carbon Fiber Endcap Options (-RB, -LB-C, and -XLB-C)

Carbon Fiber is as strong as Al, Mg, and Cu, creates less background, does not corrode, and can detect energies less than 10 keV.

This lower background material allows for lower Minimum Detectable Activity (MDA) for a specific counting time, which provides another step in increasing sample throughput in low-background counting applications. The lower Z of Carbon Fiber provides a low-energy window without the additional background found in most alloys. See Figures 5 and 6 for transmission characteristics of the Be and carbon fiber windows.

Carbon Fiber, unlike Beryllium, is non-toxic and can be cleaned with most laboratory solvents such as methanol, trichloroethylene, and acetone. Soap and water may also be used. Abrasive cleaners should not be used.

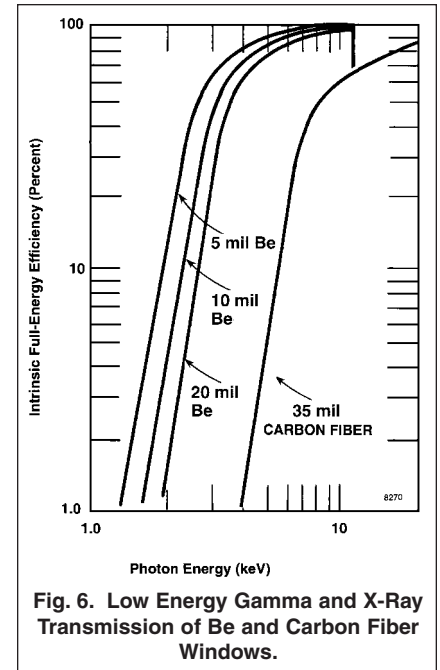
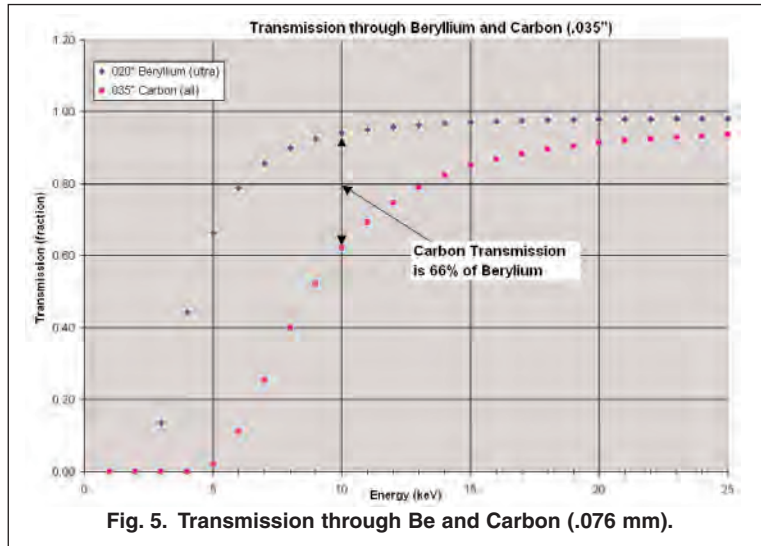

Defining the Detector Model

- See ordering information for option compatibility.

Base Model (example)	PopTop or Streamline	Endcap Diameter	Window Option (if required)	Preamplifier Option (if required)	High Voltage Option (if required)
GEM10	P4 (PopTop) (Streamline)	-70 -76 -83 -95 -108	-RB -HE -LB-C -XLB-C	-PL -HJ	-SMP

GEM Series Coaxial HPGe Detector Product Configuration Guide

Streamline Detector Capsule

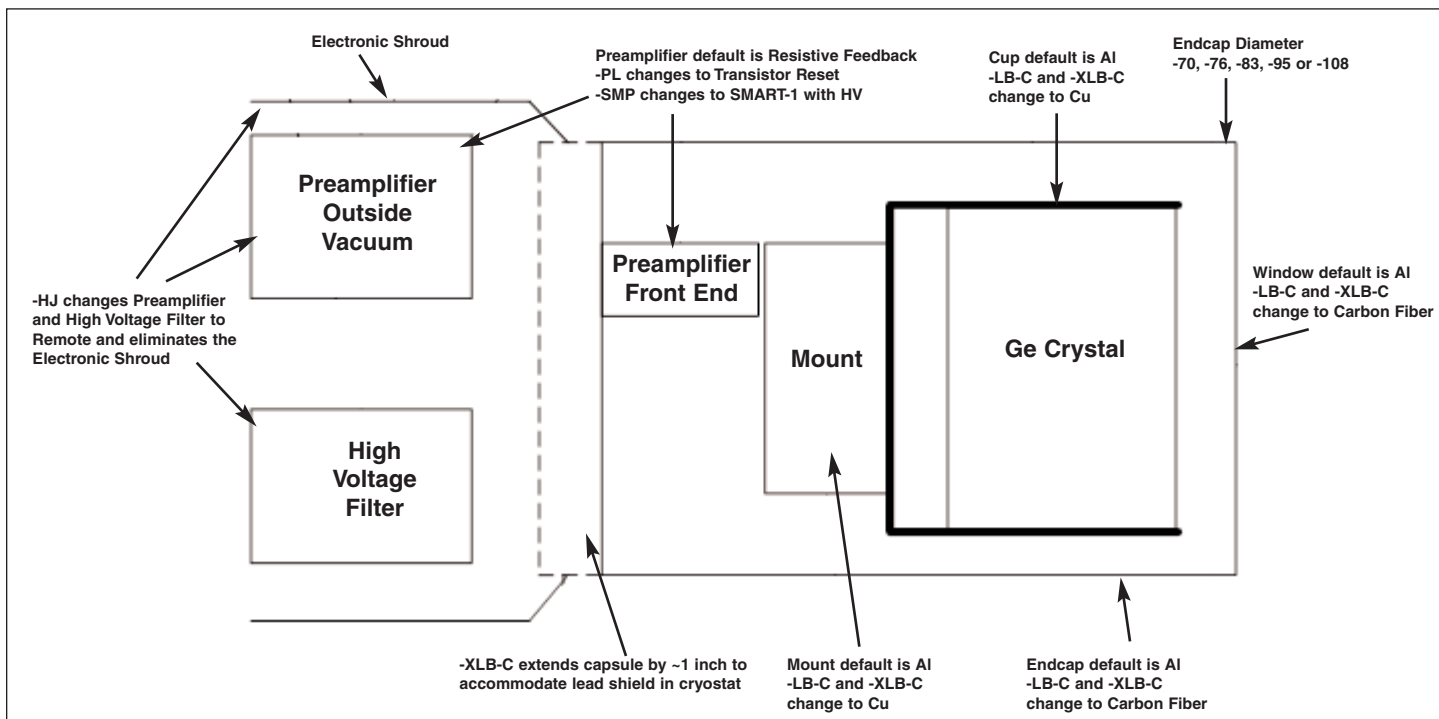

PopTop Detector Capsule

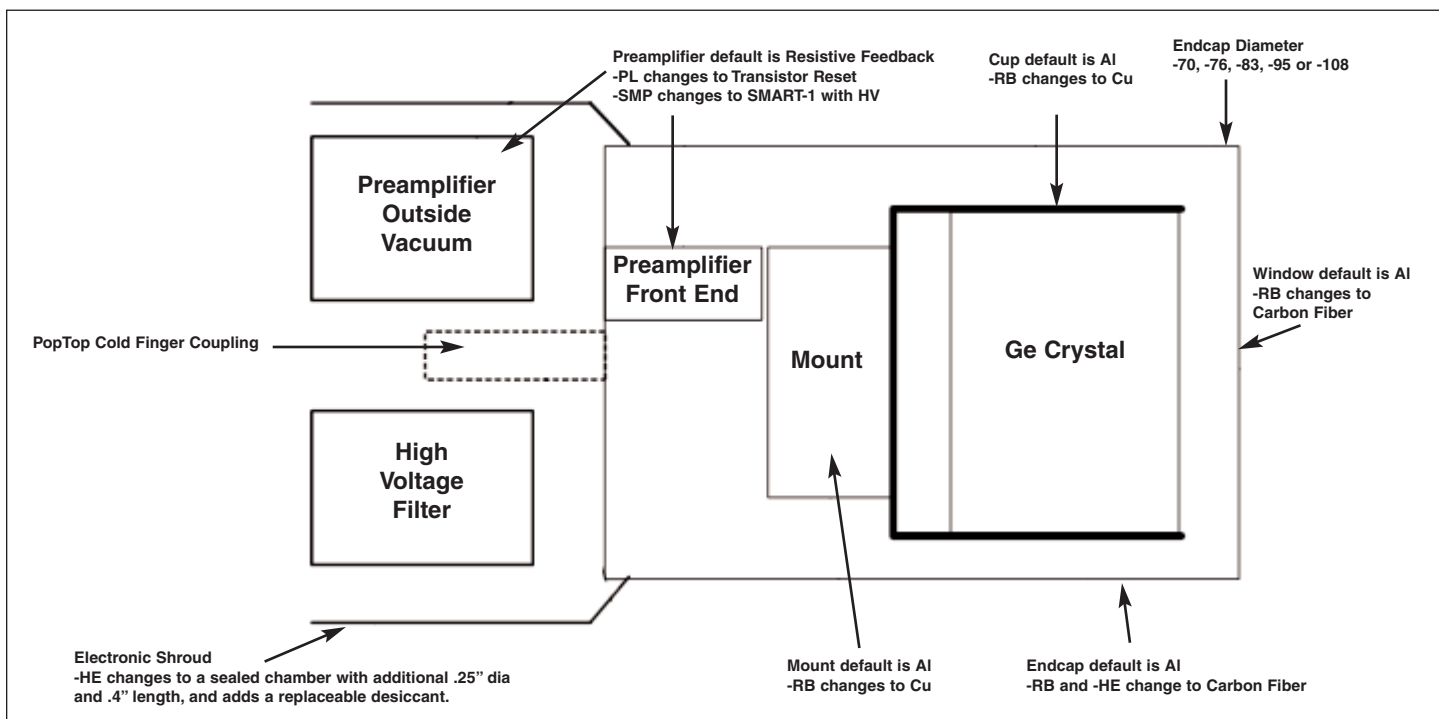

GEM Series Coaxial HPGe Detector Product Configuration Guide

Streamline Cryostat and Cryostat/Dewar Assemblies

Streamline systems (detector capsule and cryostat) share the same vacuum, requiring a cryostat or cryostat/dewar selection with the cryostat having a matching diameter to the capsule endcap.

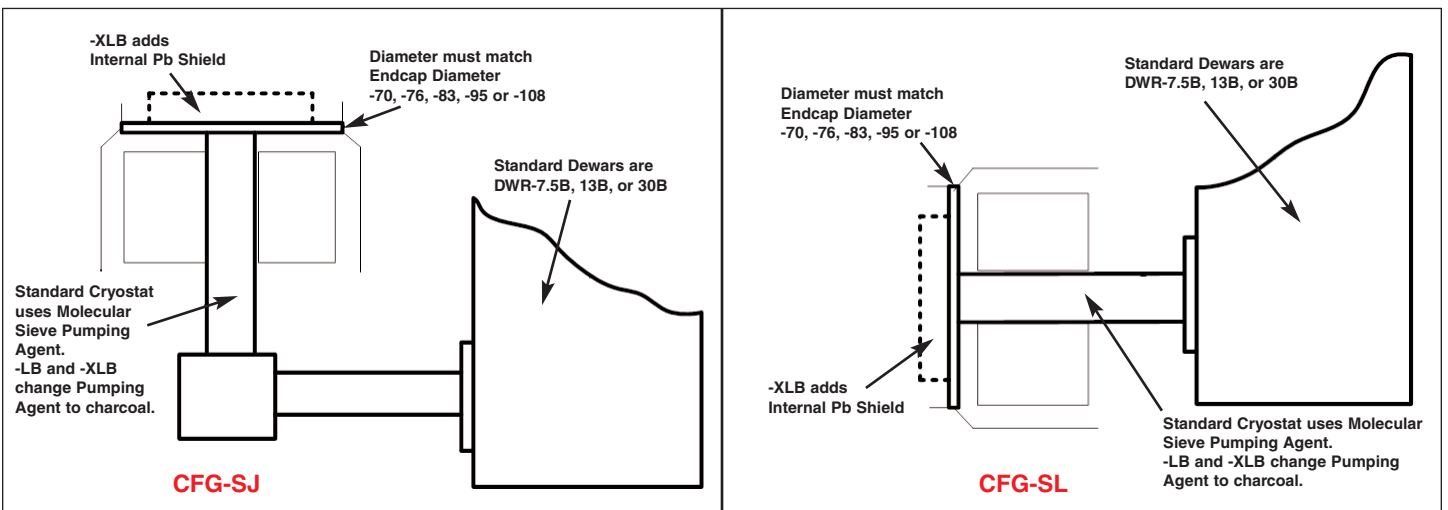
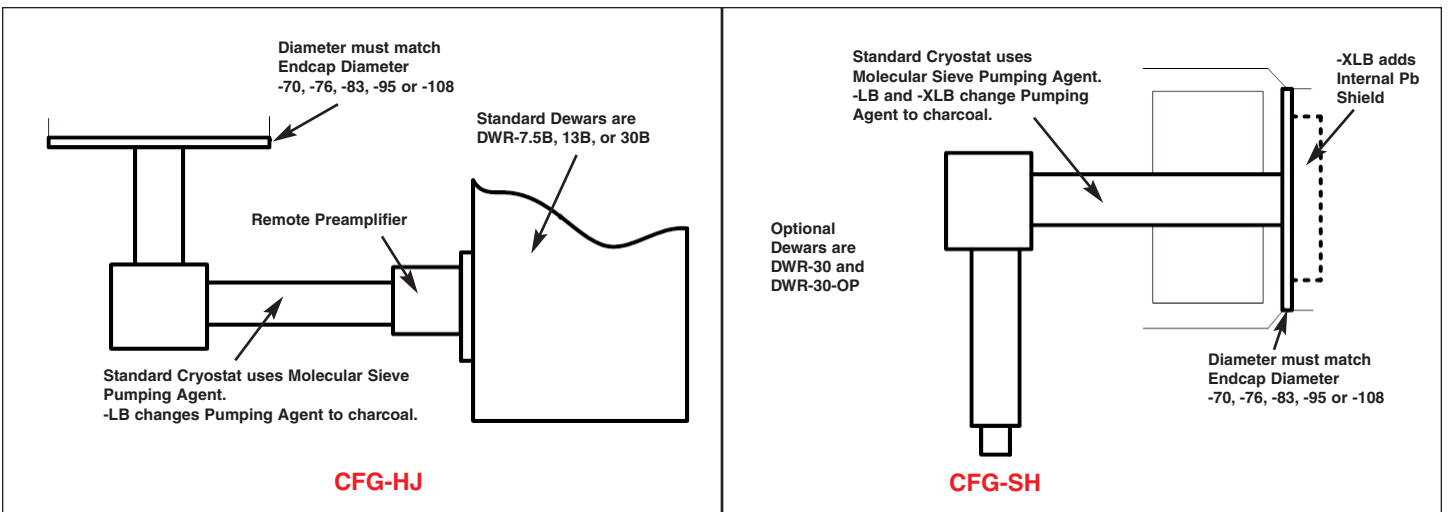
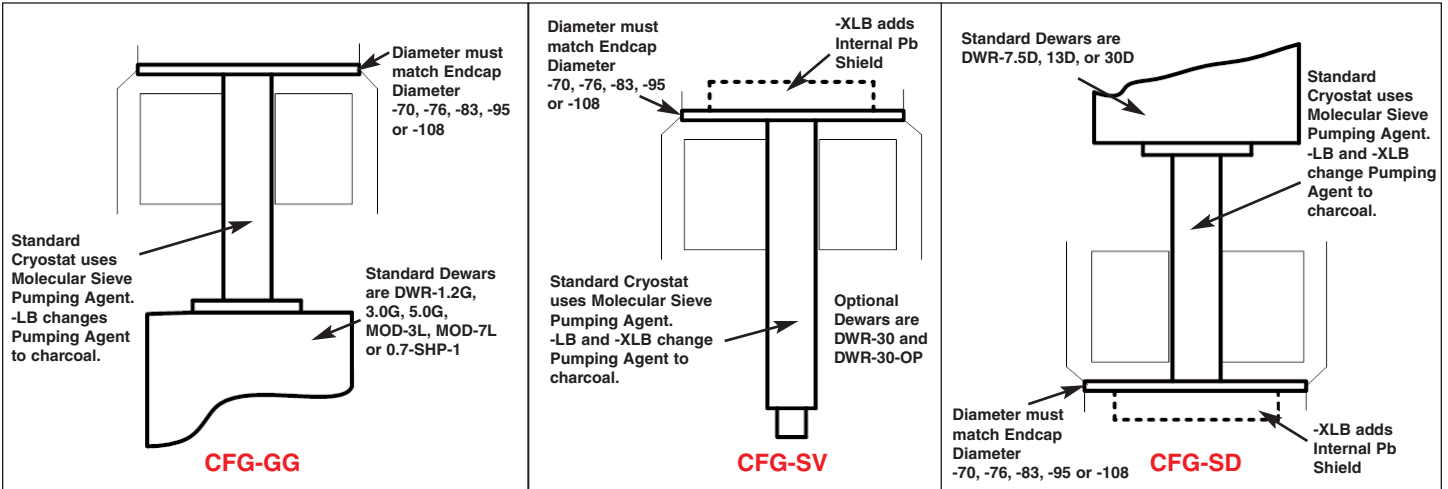

GEM Series Coaxial HPGe Detector Product Configuration Guide

PopTop and Streamline Dimensional Data

Streamline systems (detector capsule and cryostat) share the same vacuum, requiring a cryostat or cryostat/dewar selection with the cryostat having a matching diameter to the capsule endcap. A cryostat must be ordered with a Streamline capsule.

The PopTop capsule contains a vacuum unto itself. It can be mounted on any of the available cryostats, cryostat/dewar combinations, or the X-COOLER II mechanical cooling system.

The cryostat and dewar drawings that follow are to be used in conjunction with the accompanying tables of dimensions.

Note: Cryostat/Dewar drawings are NOT to scale, see tables that follow for complete dimensions.

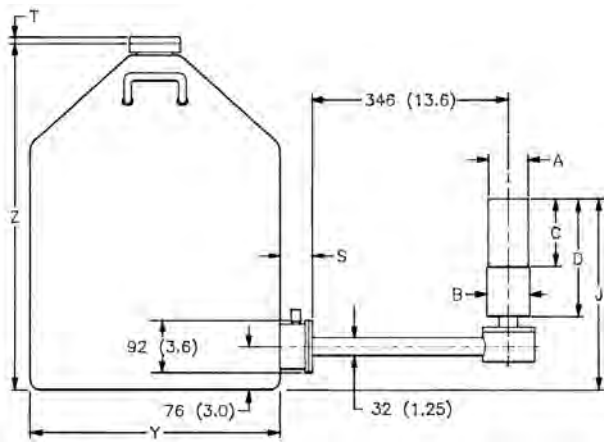

CFG-SJ, DWR-30B (or -13B or -7.5B)

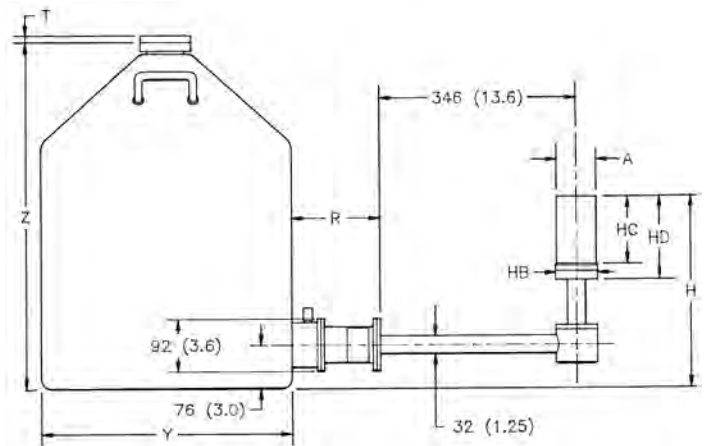

CFG-HJ, DWR-30B (or -13B or -7.5B)

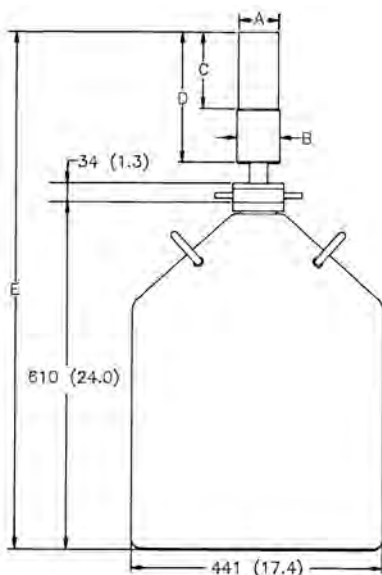

CFG-SV, DWR-30

GEM Series Coaxial HPGe Detector Product Configuration Guide

Note: Cryostat/Dewar drawings are NOT to scale, see tables that follow for complete dimensions.

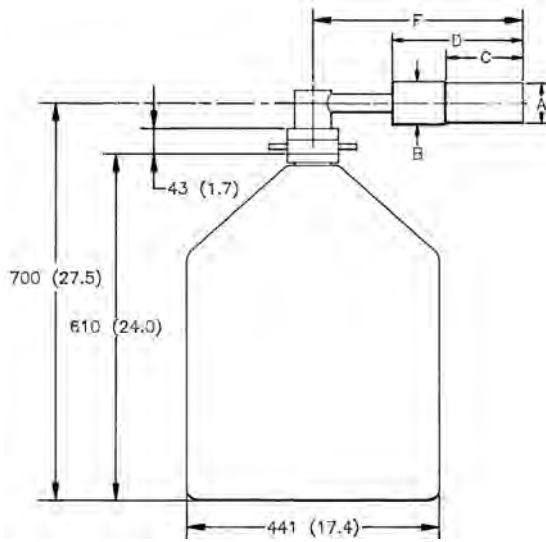

CFG-SH, DWR-30

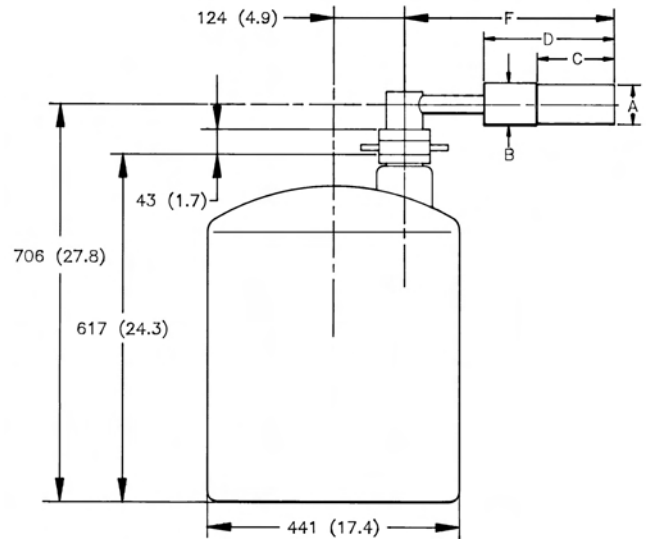

CFG-SH, DWR-30-OP

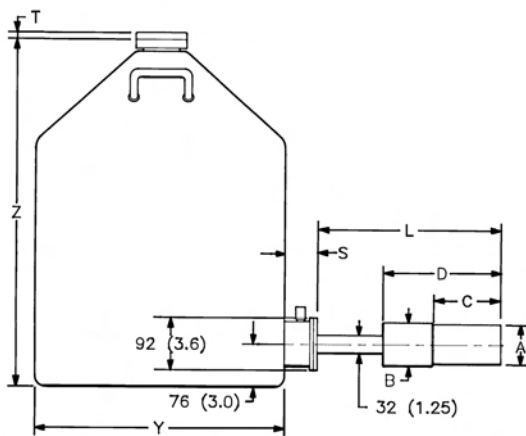

**CFG-PS4-30 (or -13 or -7.5)
or
CFG-SL, DWR-30B (or -13B or -7.5B)**

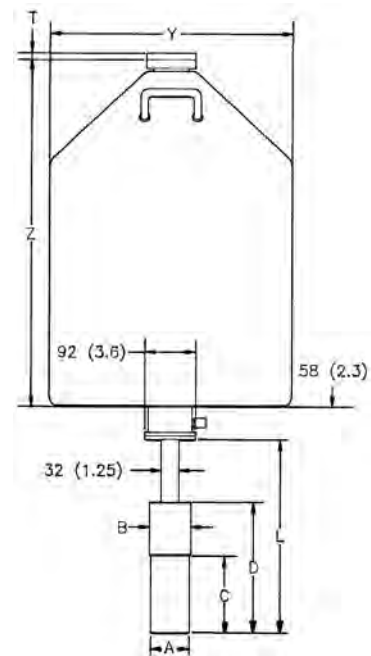

**CFG-PD4-30 (or -13 or -7.5)
or
CFG-SD, DWR-30D (or -13D or -7.5D)**

GEM Series Coaxial HPGe Detector Product Configuration Guide

Note: Cryostat/Dewar drawings are NOT to scale, see tables that follow for complete dimensions.

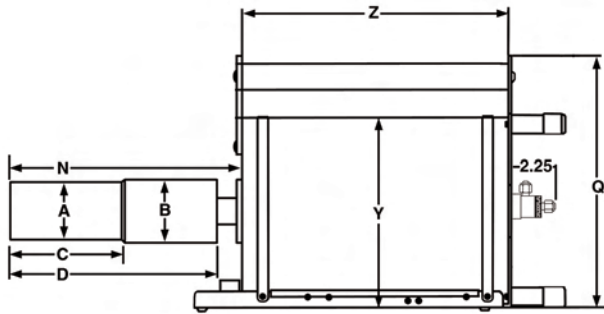

**CFG-PG4-1.2 (or -3 or -5)
or
CFG-GG, DWR-1.2G (or -3.0G, -5.0G)**

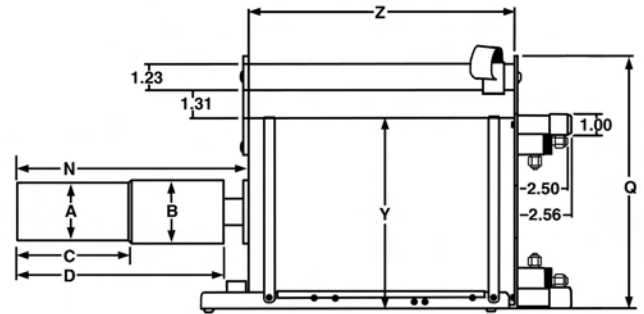

**CFG-PMOD4-3 (or -7)
or
CFG-GG, DWR-MOD3L (or -MOD7L)**

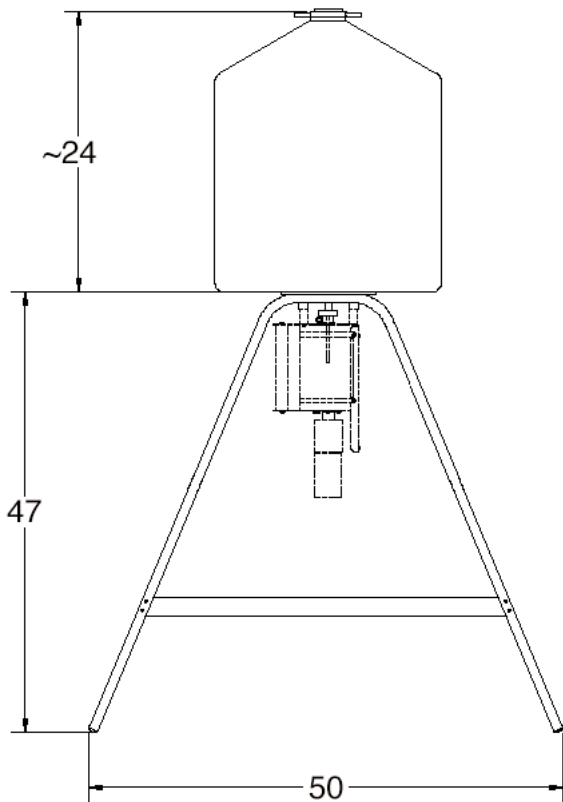

DWR-S/F

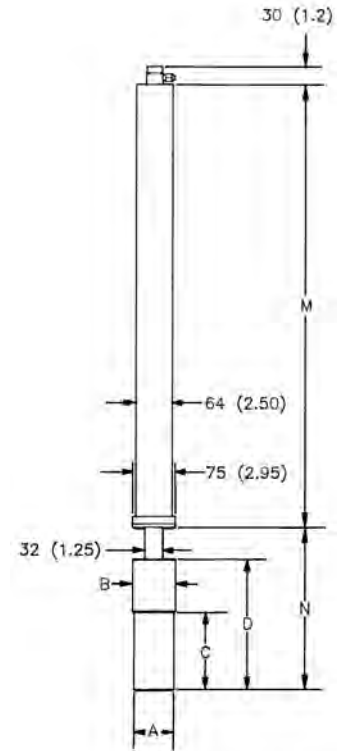

**CFG-PSHP4
or
CFG-GG, DWR-0.7-SHP-1**

GEM Series Coaxial HPGe Detector Product Configuration Guide

Note: Cryostat/Dewar drawings are NOT to scale, see tables that follow for complete dimensions.

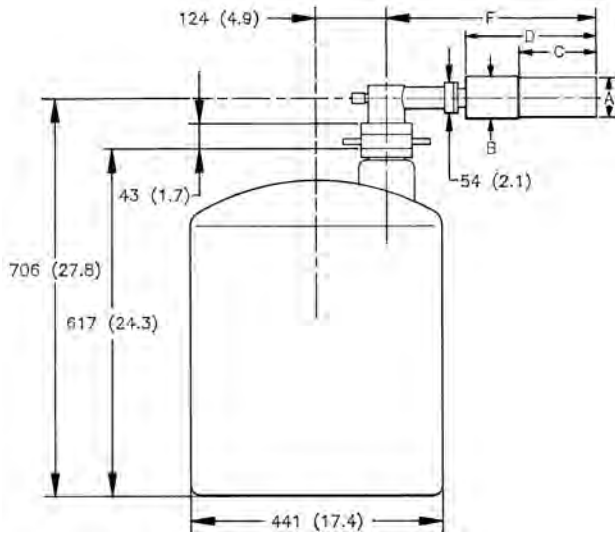

CFG-PH4, DWR-30-OP

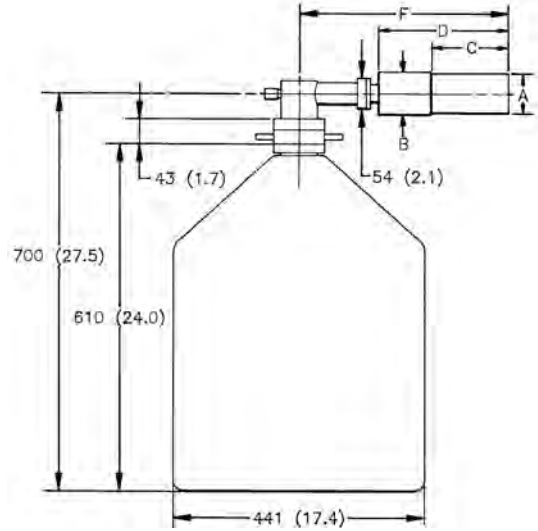

CFG-PH4, DWR-30

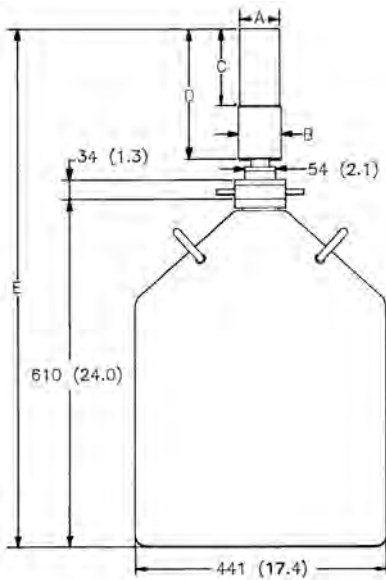

CFG-PV4, DWR-30

GEM Series Coaxial HPGe Detector Product Configuration Guide

GEM Endcap Diameters

Note that there is an “overlap” of coaxial detector efficiency versus endcap diameter. For example, a 25–35% efficiency detector, depending on diameter, may fit in either a -70, -76 or -83 size endcap. The endcap size must be specified by adding the endcap Model (-xx) to the Detector Model (e.g., GEM25-76 or GEM25P4-70).

If this, or any other dimension is critical, please specify at time of order.

Endcap Model (dia. mm)	-70	-76	-83	-95	-108
Endcap Diameter (in)	2.75	3.00	3.25	3.75	4.25
Efficiency	0–35%	25–45%	25–65%	60–110%	120–150%

PopTop GEM Detector Dimensions

- Dimensions are for reference only and subject to change.
- If dimensional constraints are critical, contact the factory.

Endcap Model (dia. mm)			-70	-76	-83	-95	-108
% Efficiencies available in this endcap size			0–35	25–45	25–65	60–110	120–150
Dim.	Unit	Tol.					
A	mm (in)	0.3 (0.01)	70 (2.75)	76 (3.0)	83 (3.25)	95 (3.75)	108 (4.25)
B	mm (in)	0.3 (0.01)	75 (2.95)	88 (3.45)	88 (3.45)	100 (3.95)	113 (4.45)
C	mm (in)	5 (0.2)	134 (5.3)	165 (6.4)	168 (6.6)	193 (7.6)	207 (8.2)
D	mm (in)	8 (0.3)	250 (9.8)	282 (11.2)	282 (11.2)	309 (12.2)	323 (12.7)
E	mm (in)	18 (0.7)	942 (37.1)	976 (38.4)	976 (38.4)	1001 (39.4)	1014 (39.9)
F	mm (in)	10 (0.4)	396 (15.6)	429 (16.9)	429 (16.9)	455 (17.9)	469 (18.5)
G	mm (in)	10 (0.4)	X X	X X	X X	X X	X X
H	mm (in)	18 (0.7)	X X	X X	X X	X X	X X
HB	mm (in)	0.3 (0.1)	X X	X X	X X	X X	X X
HC	mm (in)	5 (0.2)	X X	X X	X X	X X	X X
HD	mm (in)	10 (0.4)	X X	X X	X X	X X	X X
J	mm (in)	18 (0.7)	X X	X X	X X	X X	X X
L	mm (in)	10 (0.4)	338 (13.3)	371 (14.6)	371 (14.6)	396 (15.6)	412 (16.2)
M	mm (in)	8 (0.3)	790 (31.1)	X X	X X	X X	X X
N	mm (in)	10 (0.4)	287 (11.3)	X X	X X	X X	X X
P	mm (in)	10 (0.4)	278 (10.9)	310 (12.2)	310 (12.2)	336 (13.2)	351 (13.8)

GEM Series Coaxial HPGe Detector Product Configuration Guide

Streamline GEM Detector Dimensions

- Dimensions are for reference only and subject to change.
- If dimensional constraints are critical, contact the factory.
- CF = Contact Factory

			Standard or LB					XLB				
Endcap Model (dia. mm)			-70	-76	-83	-95	-108	-70	-76	-83	-95	-108
% Efficiencies available in this endcap size			0-35	25-45	25-65	60-110	120-150	0-35	25-45	25-65	60-110	120-150
Dim.	Unit	Tol.										
A	mm (in)	0.3 (0.01)	70 (2.75)	76 (3.0)	83 (3.25)	95 (3.75)	108 (4.25)	70 (2.75)	76 (3.0)	83 (3.25)	95 (3.75)	108 (4.25)
B	mm (in)	0.3 (0.01)	75 (2.95)	88 (3.45)	88 (3.45)	100 (3.95)	113 (4.45)	75 (2.95)	88 (3.45)	88 (3.45)	100 (3.95)	113 (4.45)
C	mm (in)	5 (0.2)	134 (5.3)	131 (5.1)	134 (5.3)	160 (6.3)	197 (7.8)	160 (6.3)	157 (6.1)	160 (6.3)	185 (7.3)	224 (8.8)
D	mm (in)	8 (0.3)	246 (9.7)	259 (10.2)	259 (10.2)	284 (11.2)	322 (12.7)	272 (10.7)	284 (11.2)	284 (11.2)	310 (12.2)	348 (13.7)
E	mm (in)	18 (0.7)	CF	CF	CF	CF	CF	CF	CF	CF	CF	CF
F	mm (in)	10 (0.4)	368 (14.5)	381 (15.0)	381 (15.0)	406 (16.0)	445 (17.5)	394 (15.5)	406 (16.0)	406 (16.0)	432 (17.0)	470 (18.5)
G	mm (in)	10 (0.4)	368 (14.5)	381 (15.0)	381 (15.0)	406 (16.0)	X X	394 (15.5)	406 (16.0)	406 (16.0)	432 (17.0)	X X
H	mm (in)	18 (0.7)	351 (13.8)	364 (14.3)	364 (14.3)	390 (15.3)	428 (16.9)	X X	X X	X X	X X	X X
HB	mm (in)	0.3 (0.1)	73 (2.9)	85 (3.4)	85 (3.4)	98 (3.9)	111 (4.4)	X X	X X	X X	X X	X X
HC	mm (in)	5 (0.2)	134 (5.3)	135 (5.3)	135 (5.3)	160 (6.3)	199 (7.8)	X X	X X	X X	X X	X X
HD	mm (in)	10 (0.4)	162 (6.4)	175 (6.9)	175 (6.9)	200 (7.9)	238 (9.4)	X X	X X	X X	X X	X X
L	mm (in)	10 (0.4)	338 (13.3)	351 (13.8)	351 (13.8)	376 (14.8)	414 (16.3)	363 (14.3)	376 (14.8)	376 (14.8)	401 (15.8)	X X
M	mm (in)	8 (0.3)	516 (20.3)	X X	X X	X X	X X	516 (20.3)	X X	X X	X X	X X
N	mm (in)	10 (0.4)	244 (9.6)	X X	X X	X X	X X	269 (10.6)	X X	X X	X X	X X

GEM Series Coaxial HPGe Detector

Product Configuration Guide

Gamma Gage and Side-Looking Dewar Dimensions

- Dimensions are for reference only and subject to change.
- If dimensional constraints are critical, contact the factory.

			Cryostat/Dewar or Dewar Type								
			CFG-PG4 and DWR-x.xG			CFG-PMOD4 and DWR-MOD-xL		CFG-PS4, CFG-PD4, DWR-xxB and DWR-xxD			
			VOLUME			VOLUME		VOLUME			
Dim.	UNIT	TOL. ±	1.2L	3L	5L	3L	7L	7.5L	13L	30L	
Q	mm (in)	13 (0.5)	229 (9.0)	302 (11.9)	302 (11.9)	229 (9.0)	302 (11.9)	X X	X X	X X	
R	mm (in)	10 (0.4)	X X	X X	X X	X X	X X	174 (6.9)	174 (6.9)	155 (16.1)	
S	mm (in)	7.6 (0.3)	X X	X X	X X	X X	X X	77 (3.0)	77 (3.0)	60 (2.3)	
T	mm (in)	5 (0.2)	X X	X X	X X	X X	X X	10 (0.4)	10 (0.4)	13 (0.5)	
Y	mm (in)	5 (0.2)	157 (6.2)	229 (9.0)	229 (9.0)	157 (6.2)	229 (9.0)	224 (8.8)	307 (12.1)	442 (17.4)	
Z	mm (in)	5 (0.2)	229 (9.0)	267 (10.5)	419 (16.5)	292 (11.5)	320 (12.6)	452 (17.8)	429 (16.9)	610 (24.0)	

GEM Series Coaxial HPGe Detector Product Configuration Guide

Example Model Numbers

Streamline Configuration

GEM10-70	10% efficiency GEM detector with 70-mm diameter endcap.
CFG-GG-70	Portable Gamma Gage cryostat with matching 70-mm diameter flange.
DWR-1.2G	1.2 liter all-position dewar for Gamma Gage cryostat.
GEM35-76-SMP	35% efficiency GEM detector with 76-mm diameter endcap and SMART-1 preamplifier and high voltage supply.
CFG-SD-76	Down-looking cryostat with matching 76-mm diameter flange.
DWR-7.5D	7.5 liter down-looking dewar.
GEM50-83-HJ	50% efficiency GEM detector with 83-mm diameter endcap and remote preamplifier and high voltage filter.
CFG-HJ-83	“J” configuration cryostat with matching 83-mm diameter flange, and remote fittings for the preamplifier and high voltage filter.
DWR-30B	30 liter side-looking dewar for “HJ” cryostat.
GEM70-95-LB-C-PL	70% efficiency GEM detector with 95-mm diameter low-background carbon fiber endcap, and Plus preamplifier.
CFG-SV-LB-95	Vertical “dipstick” style cryostat with matching 95-mm diameter flange and low-background charcoal pumping agent.
DWR-30	30 liter top port dewar that accepts “dipstick” style cryostats.

PopTop Configuration

GEM10P4-70	10% efficiency GEM detector with 70-mm diameter endcap.
CFG-PG4-1.2	Portable Gamma Gage cryostat with 1.2 liter all-position dewar.
GEM35P4-76-SMP	35% efficiency GEM detector with 76-mm diameter endcap and SMART-1 preamplifier and high voltage supply.
CFG-PD4-7.5	Downlooking cryostat with 7.5 liter dewar.
GEM50-83-HE	50% efficiency GEM detector with 83-mm diameter carbon fiber endcap with sealed preamplifier and high voltage filter.
CFG-PG4-3	Portable Gamma Gage cryostat with 3 liter all-position dewar.
GEM50P4-83-RB-SMP	50% efficiency GEM detector with 83-mm diameter reduced background carbon fiber endcap and SMART-1 preamplifier and high voltage supply.
CFG-PV4	Vertical “dipstick” style cryostat.
DWR-30	30 liter top port dewar that accepts “dipstick” style cryostats.

GEM Series Coaxial HPGe Detector

Product Configuration Guide

Ordering Information

- For Streamline, remove the “P4” from the model number.
- Endcap Diameter must be specified, see Endcap Diameter.
- FWHM = Full Width at Half Maximum; FW.1M = Full Width at One-Tenth Maximum; FW.02M = Full Width at One-Fiftieth Maximum; total system resolution for a source at 1000 counts/s measured in accordance with ANSI/IEEE Std. 325-1996, using ORTEC standard electronics. The FW.02M/FW.1M specification is typical, not warranted.
- If dimensional considerations are critical, contact factory.
- Cryostat and dewar or other cooling device are not included with detector and are required for operation.
- A cryostat must be ordered with a Streamline detector.
- Monte Carlo drawing included.

Model No.	Efficiency (%)	Resolution		Peak-to-Compton Ratio	Peak Shape		Endcap Diameter (mm)
		@122 keV (keV)	@1.33 MeV (keV)		FW.1M FWHM	FW.02M/FWHM typical	
GEM150P4	150	1.30	2.3	90:1	2.0	3.1	-108
GEM140P4	140	1.30	2.2	90:1	2.0	3.1	-108
GEM130P4	130	1.30	2.1	90:1	2.0	3.1	-108
GEM120P4	120	1.30	2.1	86:1	2.0	3.1	-108
GEM110P4	110	1.30	2.1	85:1	2.0	3.0	-95
GEM100P4	100	1.20	2.1	83:1	2.0	3.0	-95
GEM90P4	90	1.20	2.0	80:1	2.0	3.0	-95
GEM80P4	80	1.10	2.0	77:1	2.0	3.0	-95
GEM75P4	75	1.10	2.0	77:1	2.0	3.0	-95
GEM70P4	70	1.00	2.0	75:1	2.0	3.0	-95
GEM65P4	65	1.00	1.95	73:1	1.9	3.0	-83, -95
GEM60P4	60	1.00	1.95	70:1	1.9	3.0	-83, -95
GEM55P4	55	1.00	1.90	67:1	1.9	2.8	-83
GEM50P4	50	0.90	1.90	66:1	1.9	2.6	-83
GEM45P4	45	0.90	1.90	64:1	1.9	2.6	-76, -83
GEM40P4	40	0.87	1.85	64:1	1.9	2.6	-76, -83
GEM35P4	35	0.85	1.85	62:1	1.9	2.6	-70, -76, -83
GEM30P4	30	0.85	1.85	60:1	1.9	2.6	-70, -76, -83
GEM25P4	25	0.82	1.85	56:1	1.9	2.6	-70, -76, -83
GEM20P4	20	0.82	1.80	52:1	1.9	2.6	-70
GEM15P4	15	0.82	1.80	46:1	1.9	2.6	-70
GEM10P4	10	0.80	1.75	41:1	1.9	2.6	-70

GEM Detector Options

- RB PopTop Only. Reduced background PopTop capsule with Carbon Fiber endcap, add “-RB” to the model number. Not compatible with -HE option.
- HE PopTop Only. Harsh Environment Option for PopTop detectors 76 mm and larger, add “-HE” to the model number. Not compatible with -RB option.
- PL PLUS Ultra-high-count-rate Preamplifier, add “-PL” to the model number. Not compatible with -HJ option.
- SMP SMART-1 detector option for positive bias detector, add “-SMP” to the model number. Not compatible with -HJ option.
- LB-C Streamline Only. Low-Background Detector with Carbon Fiber Endcap, add “-LB-C” to the model number. Requires selection of a Low-Background LB cryostat.
- XLB-C Streamline Only. Extra-Low-Background Detector with Carbon Fiber Endcap, add “-XLB-C” to the model number. Requires selection of a Low-Background XLB cryostat. Not compatible with -HJ option.
- HJ Streamline Only. Remote preamplifier and high voltage filter for use with HJ type cryostat, add “-HJ” to the model number. Requires selection of HJ cryostat. Not compatible with -PL, -SMP, or -XLB-C options.

GEM Series Coaxial HPGe Detector Product Configuration Guide

GEM PopTop Cryostats and Dewars

• Dewar included except where marked *.

Model No.	Description
CFG-MG4-1.2G	Gamma Gage Cryostat with 1.2-liter Dewar, Pistol Grip handle and mounting holes to fit the M-1-T1 Tripod (for 83 mm or smaller endcaps)
CFG-PD4-7.5	Down-looking Cryostat with 7.5-liter Dewar
CFG-PD4-13	Down-looking Cryostat with 13-liter Dewar
CFG-PD4-30	Down-looking Cryostat with 30-liter Dewar
CFG-PG4-1.2	Gamma Gage Cryostat with 1.2-liter Dewar (for 83 mm or smaller endcaps) (not compatible with -HE option)
CFG-PG4-3	Gamma Gage Cryostat with 3-liter Dewar
CFG-PG4-5	Gamma Gage Cryostat with 5-liter Dewar
CFG-PH4	Horizontal Cryostat (Dipstick type). Includes LNTC1.5WH. Dewar not included.* Choose DWR-30 or DWR-30-OP.
CFG-PMOD4-3	Gamma Gage Cryostat with 3-liter Multi-Orientation Dewar
CFG-PMOD4-7	Gamma Gage Cryostat with 7-liter Multi-Orientation Dewar
CFG-PS4-7.5	Side-Looking Cryostat with 7.5-liter Dewar
CFG-PS4-13	Side-Looking Cryostat with 13-liter Dewar
CFG-PS4-30	Side-Looking Cryostat with 30-liter Dewar
CFG-PSHP4	Down-Looking Shallow-Hole Probe with 0.7-liter Dewar
CFG-PV4	Vertical Cryostat (Dipstick type). Includes LNTC1.5WH. Dewar not included.* Choose DWR-30 or DWR-30-OP.
DWR-30	30-liter Dewar
DWR-30-OP	30-liter Offset-Port Dewar
DWR-S/F	Storage Fill Dewar for CFG-PG4-X
CFG-X-COOL-II-115	X-COOLER II with PopTop connector using 110-120 V ac, 60 Hz Input Power
CFG-X-COOL-II-230	X-COOLER II with PopTop connector using 220-240 V ac, 50 Hz Input Power

GEM Series Coaxial HPGe Detector Product Configuration Guide

GEM Streamline Cryostats

- Select dewar from GEM Streamline Dewars. Dewar included except where marked*.
- Append matching Detector Endcap Size designation to cryostat model: -70, -76, -83, -95, -108 [e.g., CFG-SJ-95 for GEM75-95 or CFG-SL-XLB-76 for GEM25-76-XLB-C]

Model No.	Description
CFG-GG	Gamma Gage Cryostat Dewar
CFG-HJ	J-type Cryostat with Remote Preamp and Dewar. (for -HJ option only)
CFG-SD	Down-Looking Cryostat with Dewar
CFG-SH	Horizontal Cryostat (Dipstick type). Includes LNTC1.25WH. Dewar not included.*
CFG-SJ	J-type Cryostat with Dewar
CFG-SL	Side-Looking Cryostat with Dewar
CFG-SV	Vertical Cryostat (Dipstick type). Includes LNTC1.25WH. Dewar not included.*

LOW-BACKGROUND

CFG-GG-LB	Low-Background Gamma Gage Cryostat with Dewar
CFG-HJ-LB	Low-Background J-type Cryostat with Remote Preamp and Dewar. (for -HJ option only)
CFG-SD-LB	Low-Background Down-Looking Cryostat with Dewar
CFG-SH-LB	Low-Background Horizontal Cryostat (Dipstick type). Includes LNTC1.25WH. Dewar not included.*
CFG-SJ-LB	Low-Background J-type Cryostat with Dewar
CFG-SL-LB	Low-Background Side-Looking Cryostat with Dewar
CFG-SV-LB	Low-Background Vertical Cryostat (Dipstick type). Includes LNTC1.25WH. Dewar not included.*
CFG-SD-XLB	Extra-Low-Background Down-Looking Cryostat with Dewar
CFG-SH-XLB	Extra-Low-Background Horizontal Cryostat (Dipstick type). Includes LNTC1.25WH. Dewar not included.*
CFG-SJ-XLB	Extra-Low-Background J-type Cryostat with Dewar
CFG-SL-XLB	Extra-Low-Background Side-Looking Cryostat with Dewar
CFG-SV-XLB	Extra-Low-Background Vertical Cryostat (Dipstick type). Includes LNTC1.25WH. Dewar not included.*

GEM Streamline Dewars

For Cryostat	Choose	Description	
CFG-GG	DWR-1.2G	1.2-liter All-Orientation Dewar	Included with Cryostat
	DWR-3.0G	3.0-liter All-Orientation Dewar	Included with Cryostat
	DWR-5.0G	5.0-liter All-Orientation Dewar	Included with Cryostat
	DWR-MOD-3L	3-liter Multi-Orientation Dewar	Included with Cryostat
	DWR-MOD-7L	7-liter Multi-Orientation Dewar	Included with Cryostat
	DWR-0.7-SHP-1	0.7-liter Shallow-Hole Probe Dewar	Included with Cryostat
	DWR-S/F	Storage/Fill Dewar for DWR-XG	
CFG-HJ, SJ, SL	DWR-7.5B	7.5-liter Side-Looking Dewar	Included with Cryostat
	DWR-13B	13-liter Side-Looking Dewar	Included with Cryostat
	DWR-30B	30-liter Side-Looking Dewar	Included with Cryostat
CFG-SD	DWR-7.5D	7.5-liter Down-Looking Dewar	Included with Cryostat
	DWR-13D	13-liter Down-Looking Dewar	Included with Cryostat
	DWR-30D	30-liter Down-Looking Dewar	Included with Cryostat
CFG-SV, SH	DWR-30-OP	30-liter Offset-Port Dewar	
	DWR-30	30-liter Dewar	

Specifications subject to change
120409

ORTEC[®]

www.ortec-online.com

Tel. (865) 482-4411 • Fax (865) 483-0396 • ortec.info@ametek.com
801 South Illinois Ave., Oak Ridge, TN 37831-0895 U.S.A.
For International Office Locations, Visit Our Website

AMETEK[®]
ADVANCED MEASUREMENT TECHNOLOGY